

SEEKER HF Wasp Drone

User Manual V1.1

2025.01

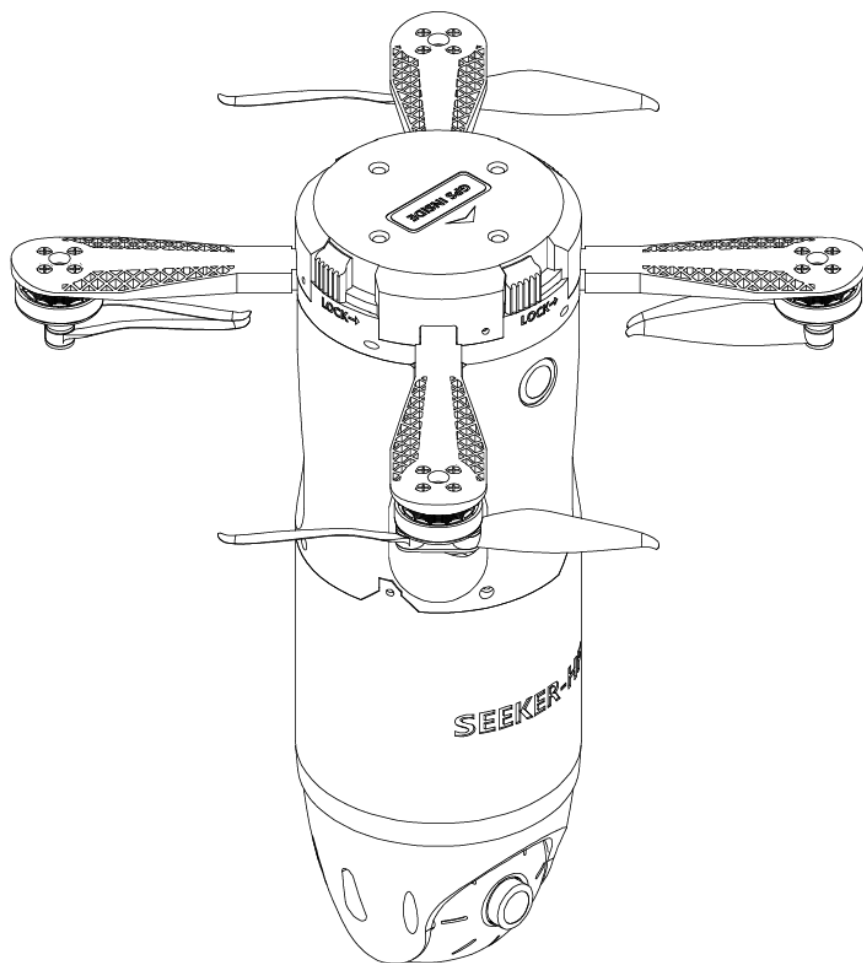

Product Usage Notes (Important!)

1. After use, place the device indoors and replace the desiccant promptly to avoid lens fogging caused by high environmental humidity. If the lens fogs up, the moisture will usually dissipate after the device is powered on for a period. The recommended storage environment has a relative humidity of less than 40% and a temperature of 20°C ±5°C.
2. The drone is not a toy and must be operated by a licensed professional pilot. Unlicensed operation is strictly prohibited.
3. The aircraft consists of many high-precision components. Do not attempt repairs unless you are a qualified professional. Incorrect repair methods may cause serious malfunctions.
4. Flying indoors is strictly prohibited. Outdoor flight requires an open area with at least a 10-meter diameter for safe takeoff and landing. An insufficient takeoff area can lead to collisions or crashes.
5. Do not frequently power the aircraft on and off. After shutdown, wait at least 50 seconds before restarting; otherwise, the camera module's lifespan may be affected.
6. The product's ingress protection (IP) rating is not permanently effective and may decrease due to wear from long-term use.
7. Ensure the aircraft's surface is dry before takeoff.
8. Before takeoff, always confirm the battery is securely installed and there are no signs of loose wiring harnesses.

9. Before opening the SD card protective cover, wipe the surface of the body clean. Do not insert or remove the SD card while the power is on.
10. Never touch high-speed rotating objects like propellers. Improper operation may cause serious personal injury!
11. Do not touch the camera lens surface coating directly with hands or scratch it with hard objects, as this will blur the camera's imaging and affect image quality.
12. When cleaning the camera lens, always use a soft, dry cleaning cloth. Do not use alkaline cleaners.

Product Overview

The SEEKER HF (X21) is a foldable, lightweight, and low-cost drone designed for special application fields, featuring advanced design concepts and excellent flight stability.

The airframe is primarily constructed from carbon fiber and high-strength nylon. Key areas, such as the launch mechanism, incorporate 15% short-cut carbon fiber to enhance impact resistance. The foldable design significantly reduces transportation costs. A unique motor layout enables mid-air deployment when used with a launch tube.

The no-load flight time reaches up to 15 minutes (measured using a high-voltage, long-endurance battery). The high-quality power system provides ample reserve, allowing the aircraft to accelerate to 100 km/h very quickly. The 150mm short wheelbase design facilitates navigation in confined spaces.

Significant Payload Capacity: Maximum deployable load of 300g.

Ingenious Structural Design: Features an innovative structure with fully independent intellectual property rights.

High Flight Speed: Equipped with a high-performance power system; maximum flight speed reaches 100 km/h in manual mode.

Long Endurance: Up to 15 minutes in no-load mode, enabling more tasks per flight.

High Image Quality: Equipped with a high-definition camera and video transmission system offering 20ms low latency for rapid pilot response.

Rapid Takeoff Readiness: From battery insertion to flight readiness in just 8 seconds.

High Structural Strength: Carbon fiber and high-temperature nylon composite material balances strength and lightweight properties, enhancing durability.

Integrated Locking Mechanism: Built-in locking buckles prevent arm movement during flight, improving performance in complex environments like jungles or indoors.

Single-Axis Gimbal: Integrated single-axis gimbal allows for camera angle adjustment via the remote controller.

Comprehensive Protection: Enclosed body provides dustproof, waterproof, and shockproof protection for operation in harsh environments.

Environmental Adaptability: Fully protected airframe allows flight in high temperature, extreme cold, strong wind, rain, and snow conditions.

Full Domestic Sourcing: Utilizes entirely domestic chips and technology.

Ease of Maintenance: Advanced design allows for full maintenance using just one type of screwdriver.

Controllable Cost: Highly customizable with an autonomous supply chain, resulting in low overall cost.

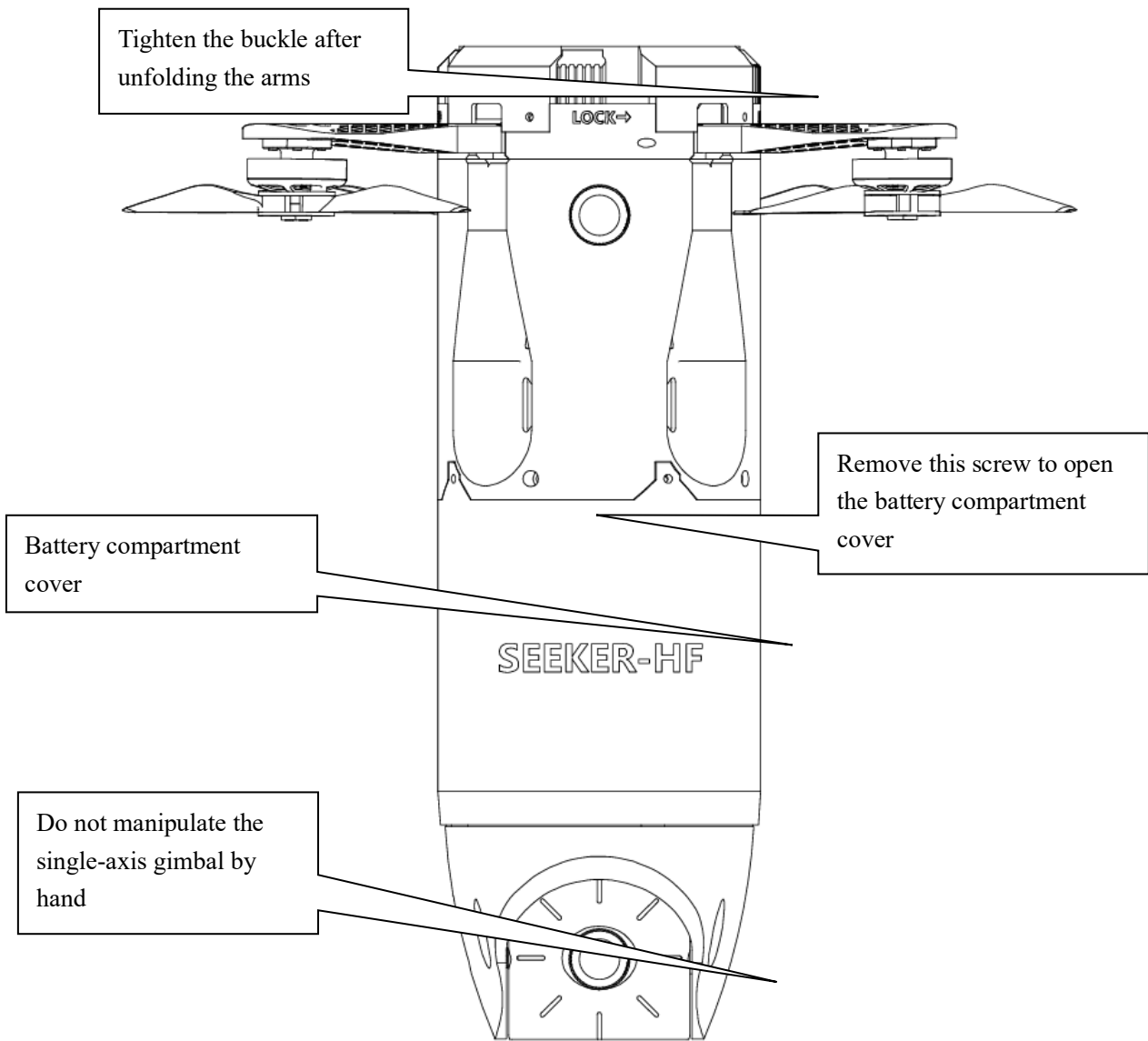

Pre-flight Preparation (Important!)

1. Install the video transmitter (VTX) and receiver antennas securely.
2. Check the remote controller and monitor battery levels; ensure they are sufficient.
3. Check the aircraft battery voltage; ensure each cell voltage is above 3.7V.
4. Check the propeller condition; ensure each propeller blade is undamaged (no cracks, etc.).
5. Preheat the aircraft for 1 minute in an open outdoor area before each takeoff.
6. Check the aircraft's flight mode selector. For multi-rotor flight, ensure it is in Altitude Hold mode. For FPV (first-person view) flight, ensure it is in Self-leveling/Stabilized mode.
7. After the flight controller and camera have preheated, and ensure the takeoff area is clear of people and vehicles, takeoff is permitted.
8. Take off in Altitude Hold mode. Switch to Position Hold mode after climbing above 2 meters.

This page contains critical safety information. Retain it and verify all conditions are met before each flight.

Takeoff Tutorial (Required Reading)

1. Place the aircraft on level ground.
2. Turn on the remote controller.
3. Install the aircraft battery and secure the battery compartment cover.
4. Check the remote controller data display; ensure the aircraft battery level is full.
5. Pull the throttle stick down to its lowest position.
6. Engage the arm/disarm switch on the remote controller; the propellers will start.
7. Gently push the throttle stick upward for takeoff.
8. If the screen displays "No Signal" on startup, re-initiate frequency pairing. With the aircraft powered on, double-click the pairing button on the back of the screen to start automatic pairing (takes approx. 10 seconds).



Aircraft Parameters

Model: SEEKER HF

Takeoff Weight: Approx. 400 g

Dimensions: 80 x 245 mm

Diagonal Wheelbase: 230 mm

Max Ascent Speed: 10 m/s (Normal & Sport modes)

Max Descent Speed: 10 m/s (Normal & Sport modes)

Max Horizontal Flight Speed: 10 m/s (Normal mode) / 50 m/s (Manual mode)

Max Hover Endurance: Approx. 15 minutes (Significantly reduced in low temperatures)

Max Flight Range: 10 km

Max Wind Resistance: 10.7 m/s (Level 5 wind)

Operating Temperature: -20°C to 40°C

Transmit Power (EIRP): 5.8 GHz (600 mW), 2.4 GHz (100 mW)

Number of Antennas: 2 (Dual antennas)

Imaging Sensor

Sensor Size: 1/1.8 inch Starlight-grade sensor

Effective Pixels: 1800 TVL

Lens:

Field of View (FOV): 165°

Focal Length: 2.1 mm

Focus Mode: Auto

Focus Range: 0.6 m to Infinity

Features: SUPER WDR technology, ultra-wide dynamic range, ultra-low noise, anti-interference, anti-vibration.

Gimbal

Pitch Range: -90° to +90° (Manual adjustment)

Real-time image stabilization: Not supported.

Flight Battery

Capacity: 1500 mAh

Nominal Voltage: 14.76 V

Charge Limit Voltage: 17.0 V

Type: Li-ion

Discharge Rate: Typical: 20C

Weight: Approx. 460 g

Charging Temperature: 5°C to 40°C

Video Transmission (VTX)

Frequency: 5.725 - 5.850 GHz

Channels: 40 CH

Quality: 720p @ 60fps

Latency: < 30 ms

Max Range: 5 km (Unobstructed, ideal conditions)

Audio Transmission: Not supported

Operating Temperature: -10°C to 40°C

